

The Kytola® Constant Flow Regulator Model 3631 is designed to provide a constant flow of liquids in applications where supply or backpressure varies. It also provides a constant flow of gases in applications where backpressure varies.



Model 3631 equipped with model L flow meter

- For liquid and gas
- High performance
- Reliable operation
- Easy maintenance
- Max. flow
1.5 L/min H₂O
60 NL/min air (6 barg)

ISO 9001 ISO 14001

CONSTANT FLOW REGULATOR WITH ALARM 3631

Model 3631 is a membrane type differential pressure controller with alarm function. It is supplied with Model L variable area flow meter for flow rate indication and setting.

FEATURES

- Adjustable alarm flow rate
- Aluminium or stainless steel construction
- Vertical installation
- Competitively priced

TYPICAL APPLICATIONS

- Water purging for instruments
- Air purging in level measurements
- Gas purging in Δp measurements

OPTIONS

- Thread adapters

Model	3631		
Max. flow	1.5 L/min H ₂ O, 60 NL/min air at 6 bar(g)	Membrane plate	Nylon (PA 6) (*PVDF)
Max. differential pressure	10 bar	Membrane	EPDM
Max. static pressure	20 bar	Mesh	PTFE
Minimum required pressure drop	2 bar	Seals	Nitrile (*Viton, EPDM)
Max. temperature	75°C (*80°C)	Alarm sensor	NAMUR or PNP/NPN (2-wire)
Body	Aluminium or stainless steel AISI 316	Connections	G 1/4" or NPT 1/4"
Spring	Stainless steel AISI 316	Weight	0.6 kg (aluminium body), 1.2 kg (AISI 316 body)
	*) Special construction on request		

3631									
Regulator Material									
Aluminium (not for H ₂ O)	A								
AISI 316	H								
Connections									
NPT 1/4"	N								
G 1/4"	R								
Flow Tube Material									
Acrylic	A								
Grilamid TR55	G								
Flow Range									
H₂O L/min	Air NL/min								
15 – 80 mL/min	0.5 – 2.5*								4C
0.01 – 0.13	0.5 – 6*								5K
0.01 – 0.2	0.5 – 7*								5A
0.025 – 0.325	1 – 10*								5B
0.05 – 0.5	2 – 14*								5C
0.1 – 0.75	3 – 20*								8T
0.1 – 1	5 – 30*								8M
0.2 – 1.6	10 – 50*								8P
Factory assigned model number for special range									XX
Scale									
H ₂ O (L/min) at +20°C	A								
Relative scale 1–10	D								
Factory assigned model number for special scale	XX								
Alarm Range									
H₂O L/min	Air NL/min*								
0 – 0.005...0.35	0 – 0.2...10*								A
0 – 0.03...0.5	0 – 1.5...17*								B
0 – 0.15...∞	0 – 3.5...∞*								C
Sensors									
Without sensor	D								
PNP/NPN (2-wire) 10 – 55 VDC	F								
NAMUR	N								
Special Features									
Hand knob in valve	H								
Viton seals	V								

*Example air ranges at +20°C / 1.013 bar (abs) for calibration purpose only

NOTE: When ordering special regulators (range or scale or both), process conditions must be mentioned as shown in the special product code example below.

NOTE: The gas scale always has to be calibrated according to the actual medium, inlet pressure, and temperature. Δp over the regulator must be ≥ 2 bar.

PRODUCT CODE EXAMPLES

Standard product code	3631HRT8TAANHV
Special product code	3631ANAXXXAFH
Medium	CO ₂
Max flow rate	13 NL/min
Min flow rate	1 NL/min
Inlet pressure	5 bar(g)
Operating temperature	+20°C
Alarm flow rate	0 – 1...10 NL/min (adjustable 1...10 NL/min, always activated 0 – 1 NL/min)

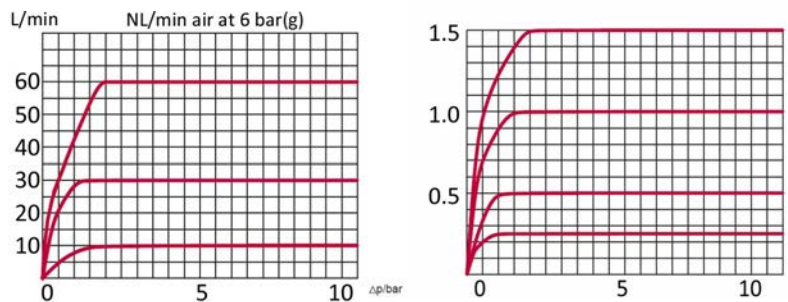
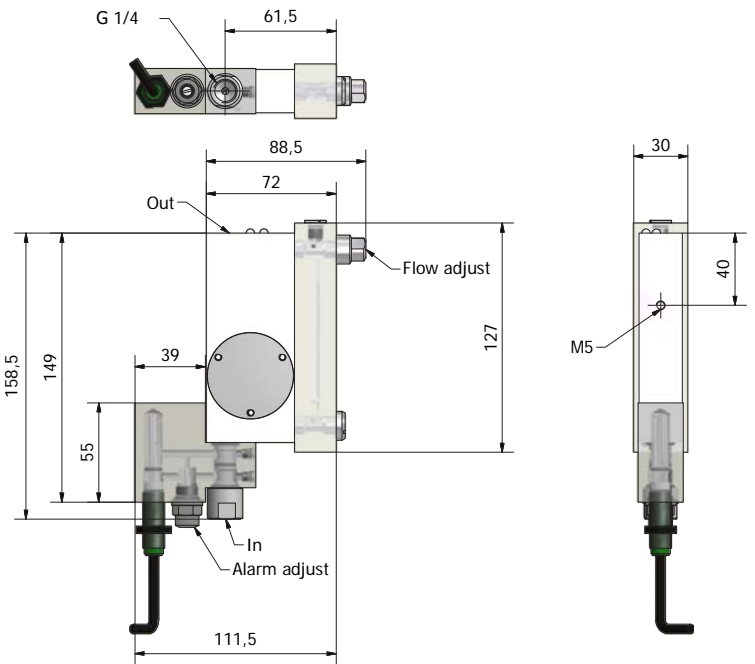

PERFORMANCE