

The KYTOLA® Oval Gear Meter Model SR1 is designed and developed for lubrication oil measurement in demanding industrial environments.

The Model SR1 oval gear meter is a positive displacement meter which always shows the correct flow rate regardless of oil temperature or viscosity changes.



- For oil
- Single channel model
- Max. 120 L/min
- Transparent cover
- Kytola coil or NAMUR sensors
- NPT or G thread connectors
- Flow adjustment valves
- ATEX version (II 2GD c TX) as option



ISO 9001 ISO 14001

OVAL GEAR METER SR1

FEATURES

Large viscosity range
30 – 1 000 cSt

Independent of viscosity and
temperature changes

Transparent cover provides highly
visible oil flow indication

Pulse output

Sturdy construction

By-pass valves for service
“on the run” (SR1-1...SR1-6)

TYPICAL APPLICATIONS

Lubrication oil flow monitoring

Industrial flow monitoring

Process control

SR1-1...6-SB

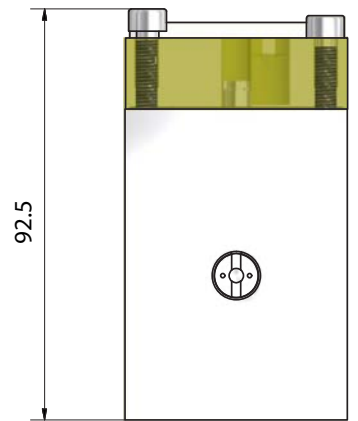
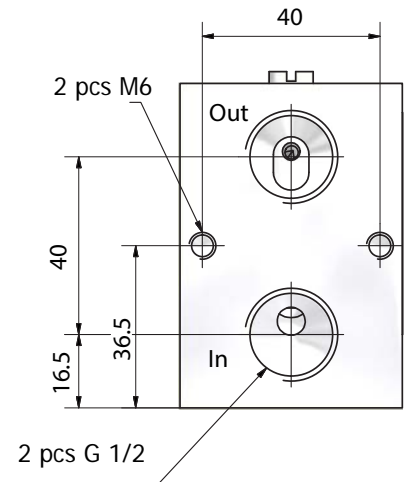
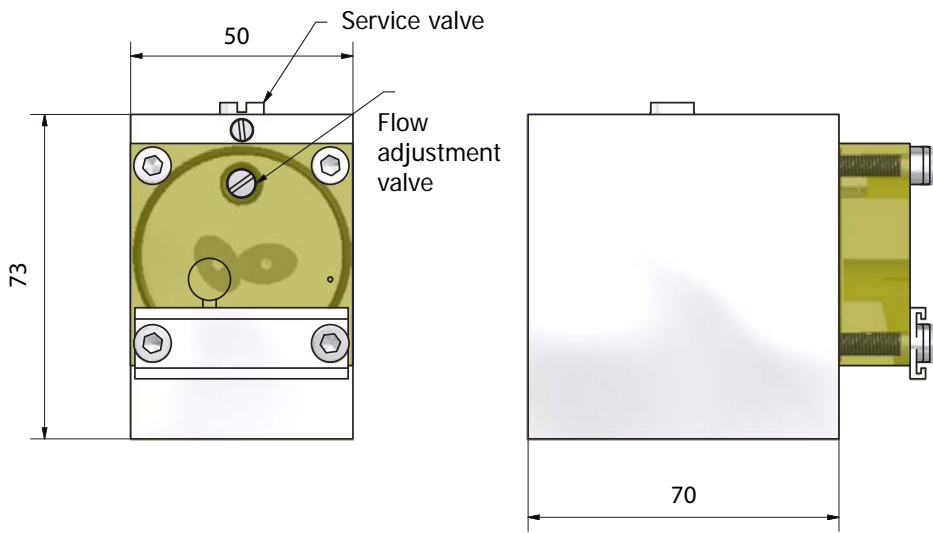

SR1-1...6-SE

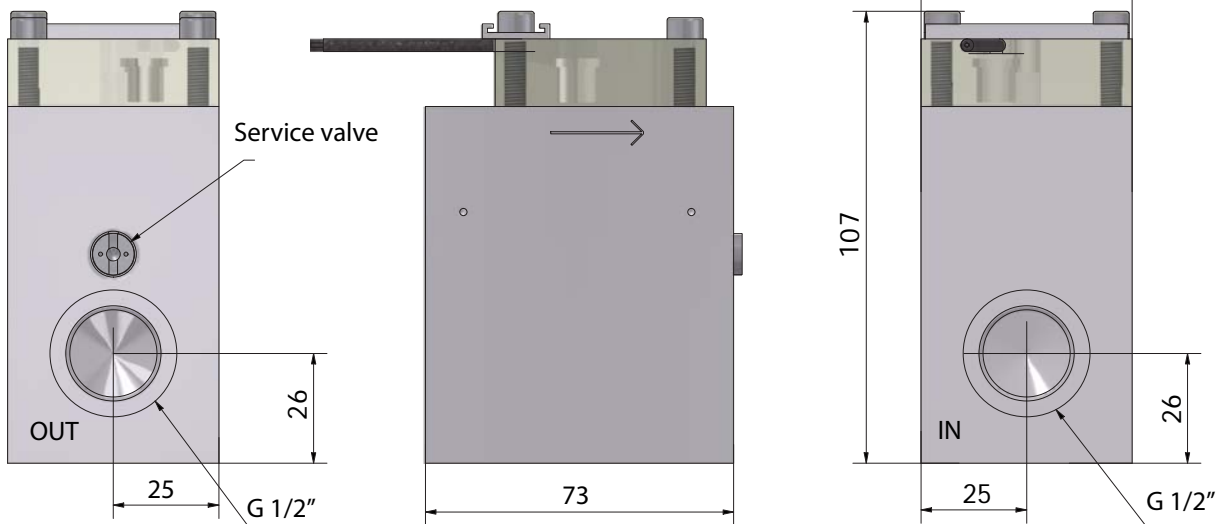
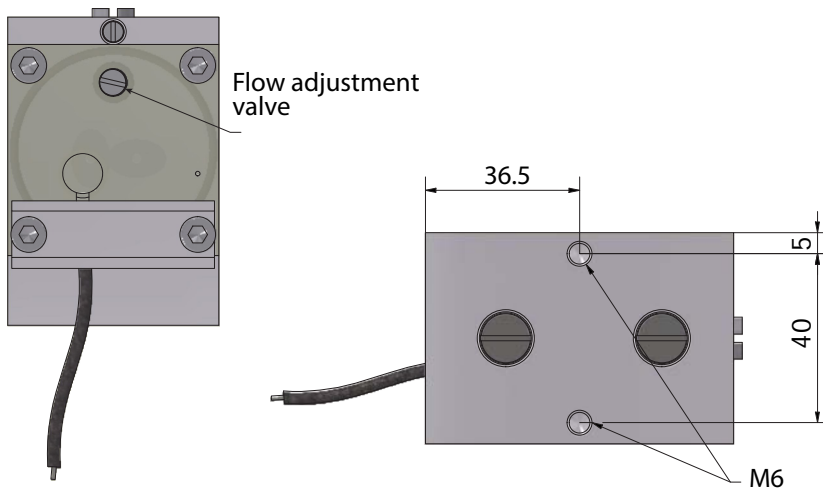

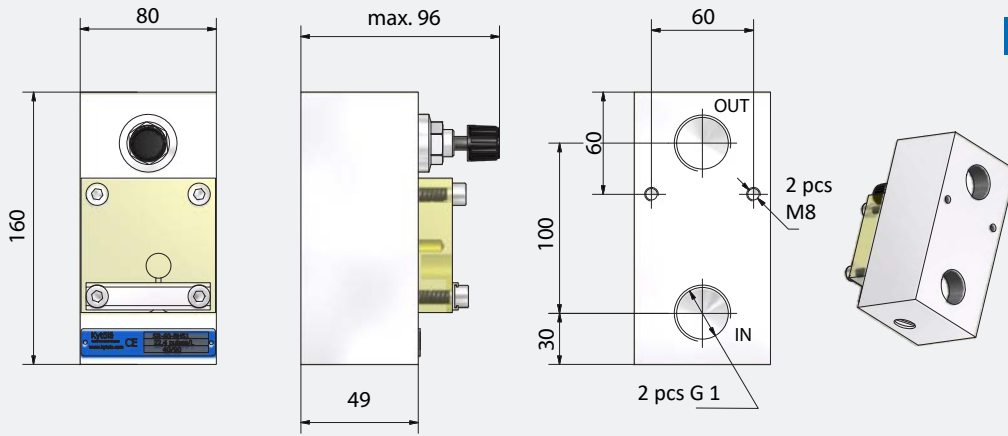

SR1-15-B, SR1-30-B

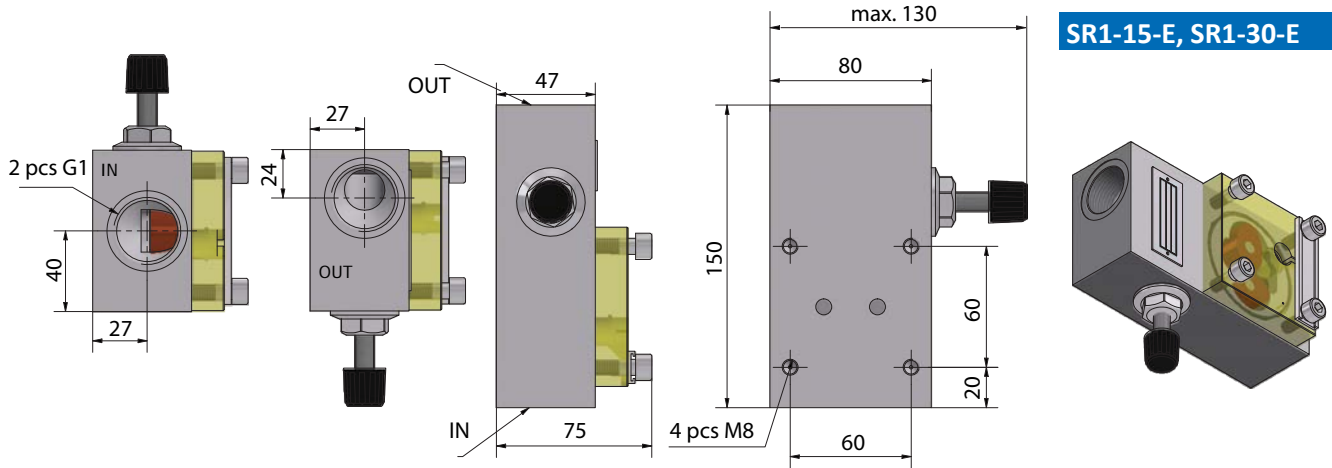

SR1-15-E, SR1-30-E

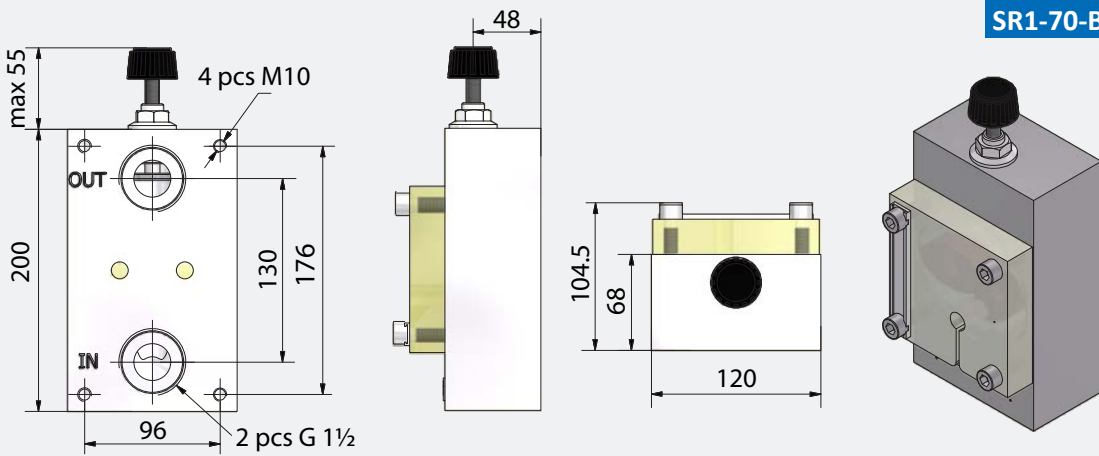

SR1-70-B, SR1-120-B

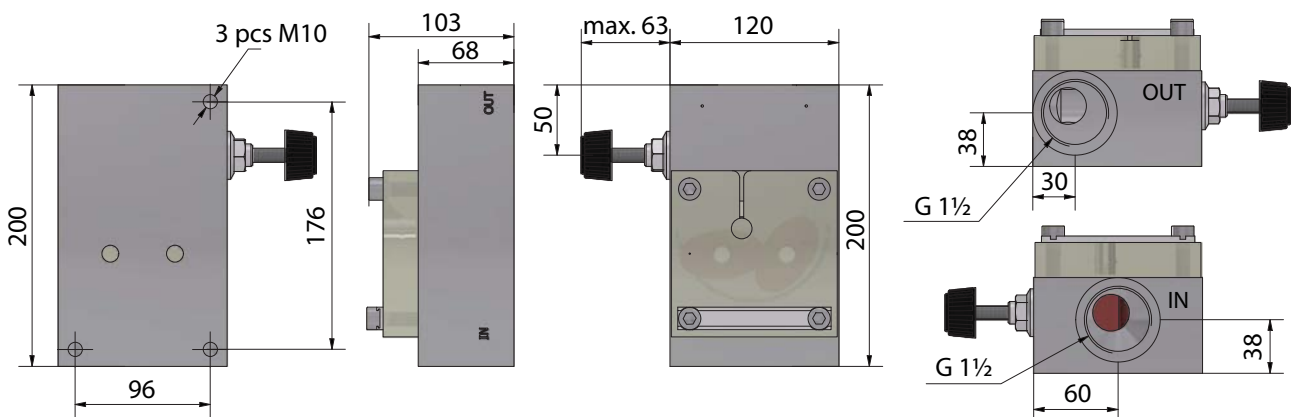

SR1-70-E, SR1-120-E

Model	SR1-1	SR1-3	SR1-6
Flow range L/min	0.1 – 1.5	0.2 – 3	0.5 – 6
Output pulses/liter	2100	1062	290
Connections G/NPT	1/2"	1/2"	1/2"
Body	Aluminium		
Gears	Composite polymer		
Cover	Polyamide		
Valve	AISI 316		
Seals	Viton®		
Sensor	Kytola coil (compatible with Kytola measuring stations) or NAMUR; EN 60947		
Max. pressure	10 bar (20 bar*)		
Max. temperature	+80°C		
Viscosity range	30–1000 cSt		
Weight	0.6 kg	0.6 kg	0.6 kg
Accuracy	±5% of reading		

Model	SR1-15	SR1-30	SR1-70	SR1-120
Flow range L/min	1 – 15	2 – 30	5 – 70	10 – 120
Output pulses/liter	126.8	75.8	22.4	17.6
Connections G/NPT	1"	1"	1½"	1½"
Body	Aluminium			
Gears	Bronze; EN 1982			
Cover	Polyamide			
Valve spindle	AISI 316			
Seals	Viton®			
Sensor	Kytola coil (compatible with Kytola measuring stations) or NAMUR; EN 60947			
Max. pressure	10 bar (20 bar*)			
Max. temperature	+80°C			
Viscosity range	30–1000 cSt			
Weight	1.7 kg	1.9 kg	5.0 kg	5.0 kg
Accuracy	±5% of reading			

* Special construction on request

SR1- [] - [] - [] - [] - []

Flow Range L/min	
1 – 15	15
2 – 30	30
5 – 70	70
10 – 120	120

Connection Type	
Back connections	B
End connections	E

Connections	
G threads	G
NPT threads	N

Sensor	
Kytola coil (compatible with Kytola measuring stations)	C
NAMUR; EN 60947	A
Without sensor (M12 x 1 thread)	D

Max. Pressure	
10 bar (standard)	blank
20 bar	7

Special Feature	
No ATEX (standard)	blank
ATEX version – only with NAMUR sensor	Z
Please choose options A and Z	Z

Standard feature: leave blank

SR1- [] - S [] - [] - [] - []

Flow Range L/min	
0.1 – 1.5	1
0.2 – 3	3
0.5 – 6	6

Service valve	
	S

Connection Type	
Back connections	B
End connections	E

Connections	
G threads	G
NPT threads	N

Sensor	
Kytola coil (compatible with Kytola measuring stations)	C
NAMUR; EN 60947	A
Without sensor (M12 x 1 thread)	D

Max. Pressure	
10 bar (standard)	blank
20 bar	7

Special Feature	
No ATEX (standard)	blank
ATEX version – only with NAMUR sensor	Z
Please choose options A and Z	Z

Standard feature: leave blank