

Kytola® Oval Gear Meter Model SRO is designed for oil flow measurement at high flow rates in demanding industrial environments.

SRO is a positive displacement meter, which always shows the correct flow rate regardless of oil temperature or viscosity changes.



- For oil
- Maximum
32 USGPM (120 L/min) or
53 USGPM (200 L/min)
- Transparent cover
- Large viscosity range
30–1000 cSt
- Pulse output

ISO 9001 ISO 14001

OVAL GEAR METER SRO

FEATURES

Independent of viscosity changes
Sturdy construction

Transparent cover provides highly visible oil flow indication

TYPICAL APPLICATIONS

Lubrication oil flow monitoring
Industrial flow monitoring
Process control

OPTIONS

Alternative sensors
G or NPT thread connections

Model	SRO-120	SRO-200
Flow range	2.6 – 32 USGPM (10 – 120 L/min)	5.3 – 53 USGPM (20 – 200 L/min)
Output	66.6 pulses/US gal (17.6 pulses/L)	32.2 pulses/US gal (8.5 pulses/L)
Connections G/NPT	1½"	1½"
Body	Aluminium	
Gears	Bronze; EN 1982	
Cover	Polyamide	
Seals	Viton®	
Sensor	NAMUR; EN 60947 (*Other types of inductive proximity sensors)	
Max. pressure	145 psi (10 bar), 290 psi (20 bar)*	
Max. temperature	+176°F (+80°C)	
Viscosity range	30–1000 cSt	
Weight	9 lbs (4 kg)	11 lbs (5 kg)
Accuracy	±5% of reading *) Special construction on request	

SRO- [] - [] - []

Flow Range		
USGPM	L/min	
2.6–32	10–120	120
5.3–53	20–200	200

Connections	
G threads	G
NPT threads	N

Sensor	
NAMUR; EN 60947	A
PNP/NPN (2-wire) 10 – 55 VDC	F
PNP (3-wire)	P
NPN (3-wire)	T
Without sensor	D

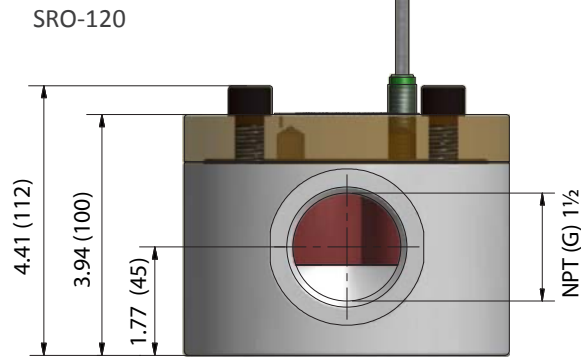
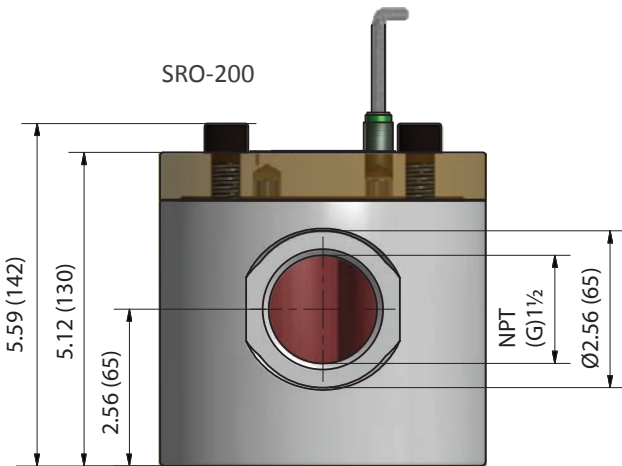
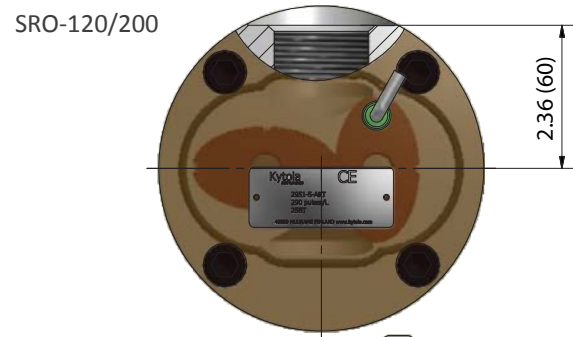
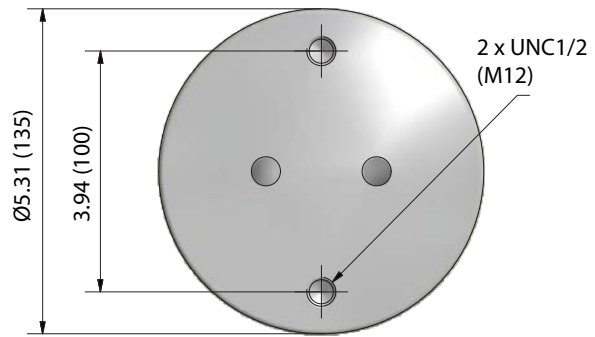

NOTE: Measurements in the drawings in this datasheet are in inches (and millimeters) if not stated otherwise.

Copyright© Kytola Instruments Oy 2021. Dimensions and measurements are given within normal tolerances. Manufacturer reserves the right to changes without prior notification. SRO_es20NA_en Published 10/2021.