

The Kytola® Variable Area Flow Meter Model EA with adjustable flow alarm is designed for applications where continuous flow control is essential.

The adjustable flow alarm and clear scale guarantees easy and reliable flow monitoring.



- For liquid and gas
- Adjustable alarm
- Adjustable flow rate
- Several flow ranges
- Various alarm sensor choices
- Scales for alternative liquids and gases

## FLOW METER WITH ADJUSTABLE ALARM EA

### FEATURES

Max. flow 2.5 L/min H<sub>2</sub>O

Max. flow 90 NL/min air  
at 1.013 bar (abs)

Max. pressure 10 bar

Max. temperature +75°C

Clear, easy-to-read scale

Reliable operation

Acrylic (PMMA) body

### TYPICAL APPLICATIONS

Heat treatment ovens

Automatic welding lines

Model	EA
Max. pressure	10 bar
Max. temperature	75°C
Accuracy	±5% F.S. (H <sub>2</sub> O +20°C)
Connections	G ¼", thread adapters must be used for NPT connections
Alarm sensor	NAMUR or PNP/NPN (optional sensors available)
Body	Acrylic (PMMA)
Alarm float	Stainless steel AISI 316
Valve housings/plugs	Nylon or stainless steel AISI 316
Valve spindles	Stainless steel AISI 316
Seals	Nitrile (*Viton, EPDM)
Weight	360 g

\*) Special construction on request

Valve Housing / Plug Material		
AISI 316	H	
Nylon	K	

Flow Range		
H <sub>2</sub> O	Air	
2 – 16 mL/min	0.1 – 0.8 NL/min*	2K
2.5 – 30 mL/min	0.1 – 1.2 NL/min*	2L
5 – 55 mL/min	0.2 – 1.8 NL/min*	2M
10 – 80 mL/min	0.4 – 2.6 NL/min*	2N
0.01 – 0.11 L/min	0.5 – 5.5 NL/min*	3K
0.02 – 0.18 L/min	0.5 – 7.0 NL/min*	3L
0.025 – 0.3 L/min	1 – 9 NL/min*	3M
0.05 – 0.45 L/min	1 – 12 NL/min*	3N
0.05 – 0.5 L/min	2 – 20 NL/min*	4B
0.1 – 1.1 L/min	2 – 36 NL/min*	4A
0.2 – 1.6 L/min	7.5 – 47.5 NL/min*	5E
0.2 – 2.2 L/min	5 – 70 NL/min*	5S
0.5 – 2.5 L/min	10 – 90 NL/min*	5F
Factory assigned number for special scale		XX

Scale		
H <sub>2</sub> O (L/min) at +20°C	A	
Air (NL/min) at +20°C / 1.013 bar (abs)	R*	
Factory assigned number for special scale	XX	

Alarm Range		
H <sub>2</sub> O L/min	Air NL/min*	
0 – 0.005...0.35	0 – 0.2...10*	A
0 – 0.03...0.5	0 – 1.5...17*	B
0 – 0.5...∞	0 – 20...∞*	C

  

Sensors		
PNP/NPN (2-wire) 10–55 VDC	F	
NAMUR	N	

Features		
Screw driver adjustable valves	blank	
Hand knobs in valves	H	
Nitrile seals	blank	
Viton® seals	V	

Standard feature: leave *blank*  
Special feature: choose character

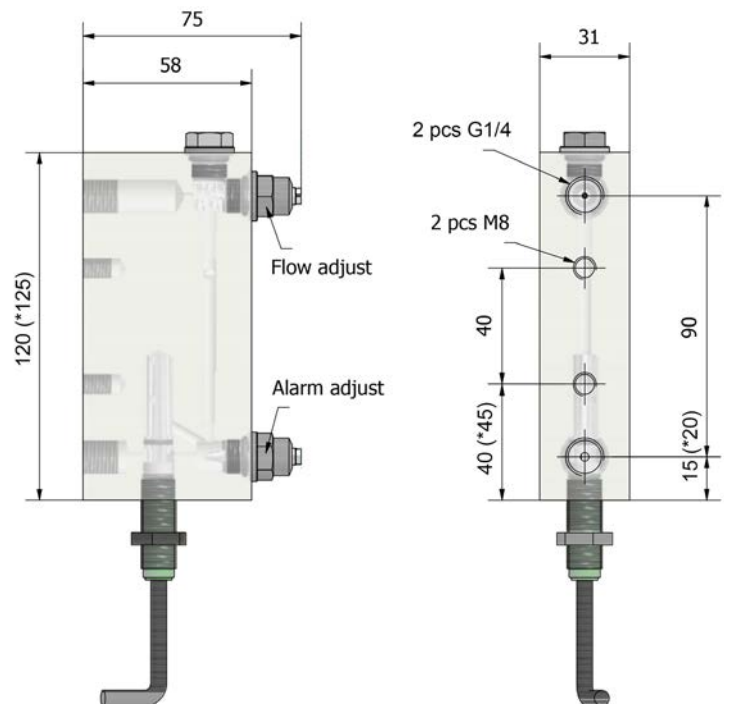

\*) Measurements only for option C (flow ranges 5E, 5S, 5F)

**NOTE:** Flow ranges 5E, 5S, 5F only with option C

**NOTE:** The gas scale always has to be calibrated according to the actual medium, inlet pressure, and temperature.

**NOTE:** When ordering special flow meters (range or scale or both), process conditions must be mentioned as shown in the special product code example below.

#### PRODUCT CODE EXAMPLES

Standard product code	EAK-2KA-AN-HV
Special product code	EAH-XXXX-BT
Medium	CO <sub>2</sub>
Max flow rate	13 NL/min
Min flow rate	1 NL/min
Operating pressure	2 bar(g)
Operating temperature	+20°C
Alarm flow rate	0 – 1...10 NL/min (adjustable 1...10 NL/min, always activated 0–1 NL/min)

\*Example air ranges at +20°C / 1.013 bar (abs) for calibration purpose only