

KYTOLA® ALARM I/O Substation is designed to transmit individual low flow alarms from Kytola variable area flow meters to control room.

The ALARM I/O Substation transmits the detected alarm to Kytola KVM Suite monitoring application or customer's PLC or DCS.



- Communication with upper level systems
- In excess of 100 substations and thousands of measuring points in one serial line
- Modbus RTU protocol
- Serial interface RS485
- NAMUR sensors

ISO 9001 ISO 14001

## SUBSTATION ALARM I/O

### FEATURES

Painted steel enclosure, IP 65

Up to 48 alarm sensors

### TYPICAL APPLICATIONS

Lubrication oil flow monitoring

Industrial flow monitoring

Process control

# ALARM I/O

# TECHNICAL DATA

## Model ALARM I/O

Enclosure	Painted steel, IP65
Supply voltage	24 VDC ±25%
Ambient temperature	-20°C...+60°C (relative humidity < 85%, non-condensing)
Communication	Modbus RTU protocol (RS485)
Flow alarms / station	Max. 48 sensors
Sensor type	NAMUR; EN 60947
Dimensions	300x200x120 mm (ALARM-I/O-48: 400x200x120 mm)
Weight	ALARM-I/O-16: 4.0 kg    ALARM-I/O-32: 4.1 kg    ALARM-I/O-48: 5.4 kg

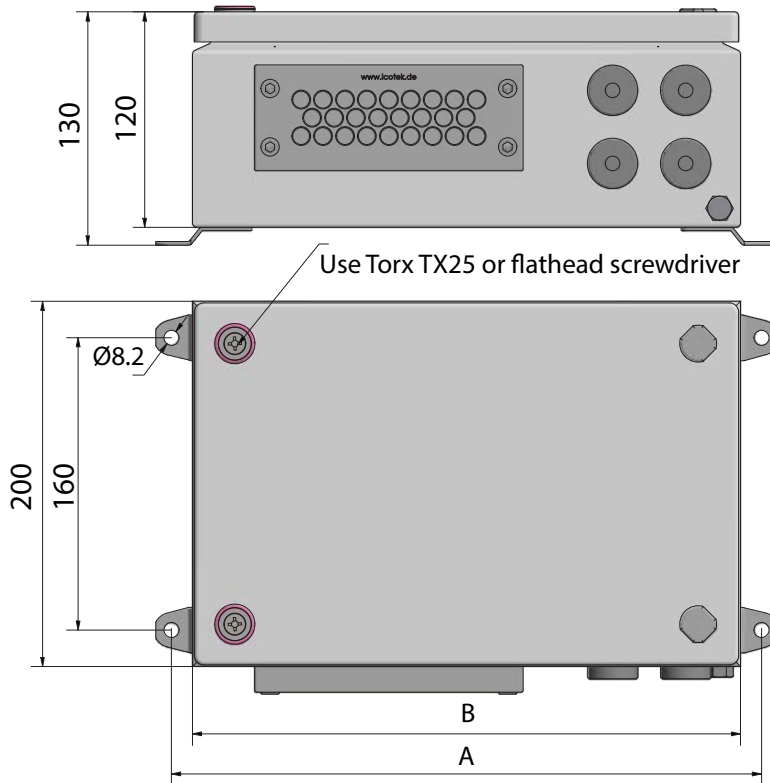

ALARM-I/O TYPE	A	B
16 and 32	320	300
48	420	400

### ALARM-I/O-

Number of Measuring Points	
16	16
32	32
48	48



## SYSTEM DESCRIPTION

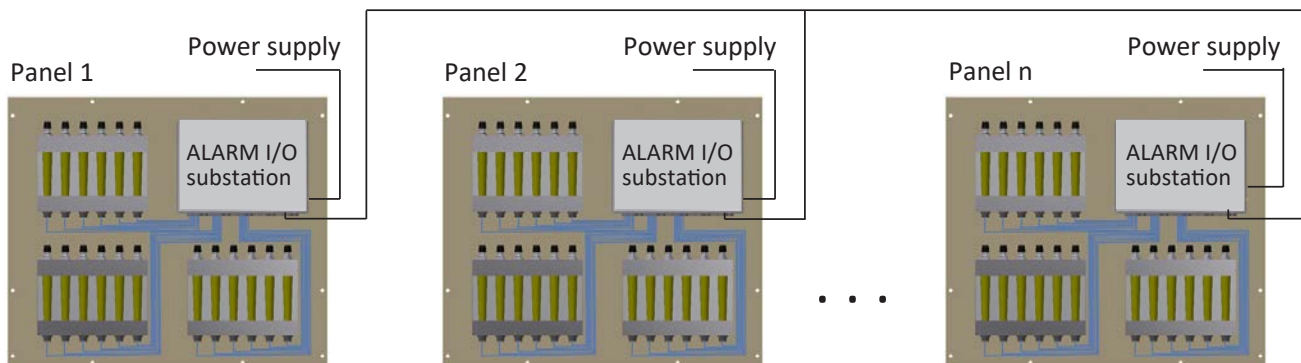

**Kytola**  
INSTRUMENTS

www.kytola.com



**Kytola Instruments Oy**  
Olli Kytölään tie 1  
FI-40950 Muurame, Finland  
Tel. +358 20 779 0690  
info@kytola.com